

This manual explains how to assemble and set up the Copy Board Series (hereinafter referred to as "this device" or "the main unit".)

### Dear Customer

The installation of this device requires specialized skills. Please do not attempt to assemble this device yourself under any circumstances.

### Dear Distributor/Installation Contractor

When installing this device, please take ample care to ensure that both the device and its mounting brackets can withstand any loads they are subjected to.

### Please Read in the Interest of Safety







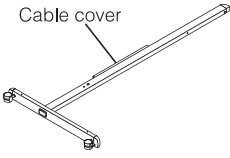

- Warning**
- Only the assembly/installation contractor should install this device.
  - Installation and assembly must be performed in accordance with this manual. Incorrect installation or assembly could result in injury.
  - Lift the main unit with 2 or more people when installing or removing. Also, make sure to lock the stand casters before installing and removing the main unit. Failure to lock the casters may lead to the stand sliding and result in an unforeseen accident.
  - When installing on a wall surface, please purchase the optional wall mounting bracket.
  - The AC adapter holder is where the AC power adapter for the main unit is stored. The AC power adapter and power cord heat up upon use, therefore please store them correctly in accordance with "Safety Precautions" of the main unit's instruction manual.

### List of packaged items

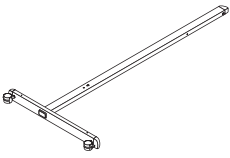
#### Main unit package

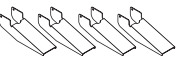
Refer to the User's Manual of the main unit. Included items vary depending on the model.

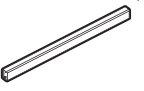
#### Stand package (optional item)

<b>Left stand leg: 1</b> 	<b>Hexagonal wrench (width across flats: 3 mm): 1</b>  <b>Hexagonal socket screws (M5 x 40): 2</b> 
<b>Right stand leg: 1</b> 	<b>Sleeves: 2</b>  <b>Stabilizers: 4</b>  <b>Hexagonal socket screws (M5 x 8): 8</b> 
<b>Horizontal bar: 1 (with 2 screws on either end)</b> 	<b>Locking knobs: 2</b> 
<b>Screw caps: 2</b> 	

### Installing the Stand (option)

#### 1 Lock the stand casters.

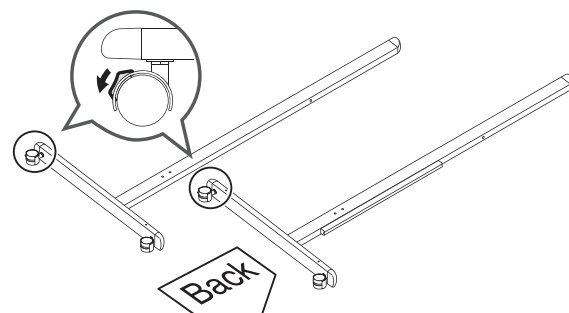

#### 2 Attach the horizontal bar to the stand legs.

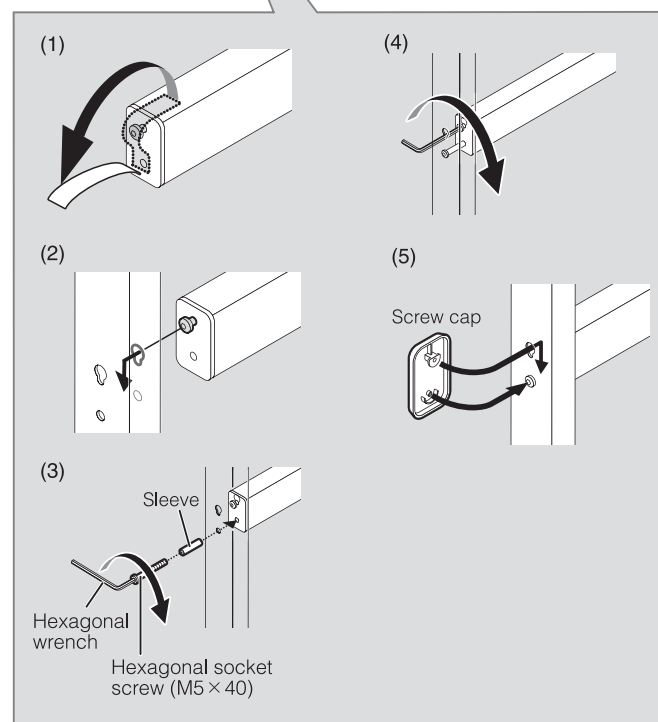
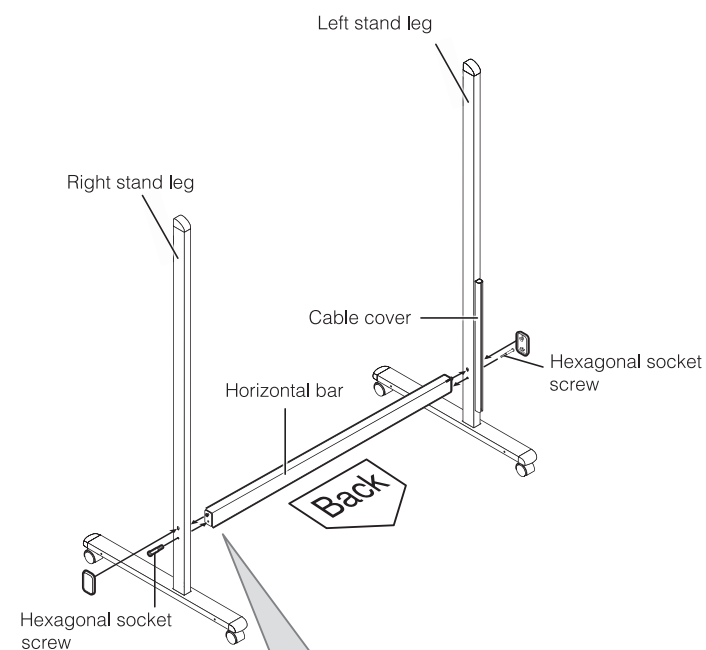

#### 3 Attach the main unit to the stand legs, and secure it with the locking knobs.



Please install the main unit on the stand with 2 or more people.



The height can be adjusted in 3 levels depending on the position of the holes on the stand used.

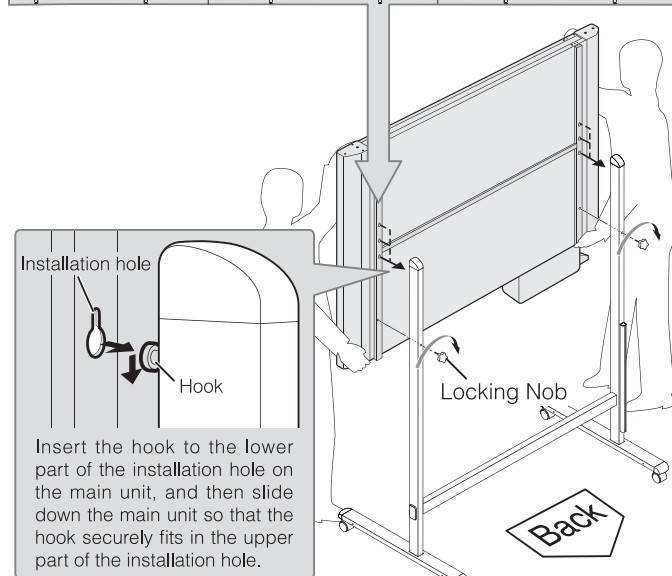
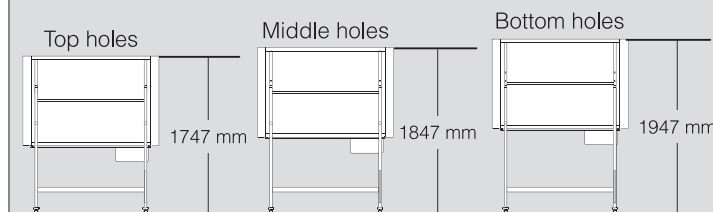

#### 4 Mount the stabilizers.

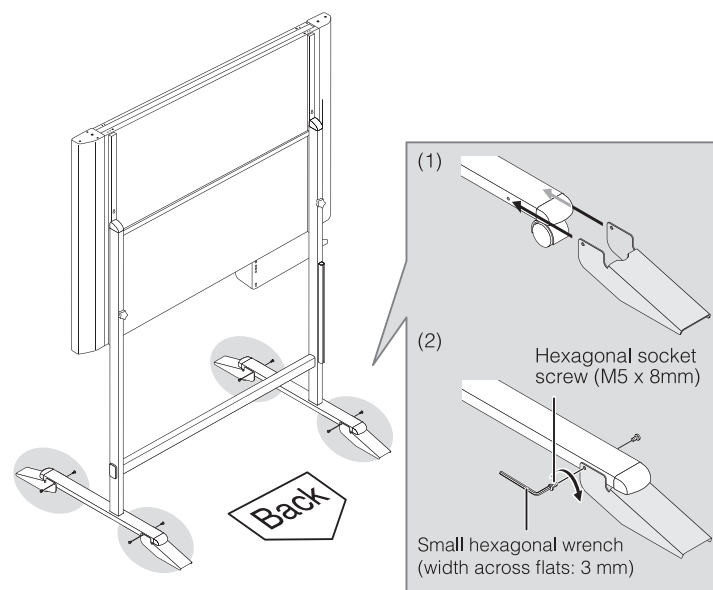

### Connecting the Cables

